

Teslameter FM 3002-0,1T (low noise)

High-precision Magnetic Field Measuring Instrument: 0.05 % of reading

High-temperature-stable: Probe < 5 ppm/K, Instrument < 5 ppm/K

Very low noise: $\leq 0.15 \mu\text{T}_{\text{eff}}$ (0.1 – 1 Hz)



- 7 ½ digit LCD display
- Measuring range 100 000.00 μT
- Resolution 0.01 μT (1/10 000 000)
- Probes 0.0005 %/K = 5 ppm/K
Instrument 0.0005 %/K = 5 ppm/K
- Analog output
- noise 0.15 μT_{eff} (0.1 – 1 Hz)
- RS 232 interface
- all key functions are PC-controlled
- Data read-out
- relative- and absolute-measurement
- filter- and integration-time displaceable
- selectable indicator extent 3 ½ - 7 ½ digits
- Factory calibration certificate with traceability

Instrument

- FM 3002-0,1T-T = desk top set
- FM 3002-0,1T-19“ = rack version

Measuring probe

- Transverse probe
- Axial probe

Options

- Probe extension cable
- Zero chamber

Teslameter FM 3002-0,1T

Description

The FM 3002 Digital Teslameter magnetic field measuring instrument is a high-precision and highly temperature independent instrument for the precise determination of magnetic induction in the range of 0 up to 100 mT with a resolution of 0.01 μ T.

The precision of the instrument is exceeded only by magnetic field measurements using nuclear magnetic resonance (NMR). The FM 3002-0,1T Teslameter has a modern 7½ digit LCD display with measuring time selectable from 0,1 s to 5 s. Further, the instrument is programmable to execute a variety of average or moving average functions. Measurements can be displayed in μ T, mT, T, G and kG. Differences (rel) from measured values (ref) can be displayed in the second line of the display.

The FM 3002-0,1T uses several methods of correction to eliminate the non-linearities and, particularly, the temperature dependence of each individual sensor. In addition to its high-resolution display, another special feature of the FM 3002-0,1T is its high precision, high stable analog output.

The noise is only 0.15 μ T_{eff} (1.5 mG_{eff}) in the range of 0.1 – 1 Hz.

Each instrument can be factory-programmed with the individual correction data of two probes (transverse or axial) so that each set will accommodate two different probes by simple re-plugging.

Both probes have the same non-linearity of max. 0.05 % of the reading \pm 0.05 % of range at a temperature coefficient of \leq 0.0005 %/K (5 ppm/K) for the transverse and axial probe.

The FM 3002-0,1T has a max. temperature coefficient of 5 ppm/K.

All values are given with nuclear magnetic resonance (NMR) measurements as reference.

By default, the FM 3002-0,1T has a serial RS 232 interface for measured data read-out and for the clear-text control of the following instrument functions: relative and absolute measurement, filter functions, sampling rate, display units, and status output.

The FM 3002-0,1T Teslameter is offered as a 2 HE 19" desk top set and as a 2 HE 19" rack unit.

Both versions come with a 7½ digit LCD display, an analog output and a RS 232 interface.

With these specifications, the FM 3002-0,1T is a new top performer.

Probe Extension Cord (Option)

Optional a probe extension cord up to 27 m is available. This can be plugged between probe and device, if a larger distance between measured object and measuring instrument has to be covered. The influence of the probe extension cord to the measured value is very low. An additional calibration is not necessary. However we recommend to omit the application of a probe extension cord where possible. With optimal accuracy and low electromagnetic susceptibility in mind it is more appropriate to extend the analog output or the RS232 interface.

Zero Chamber (Option)

Optional a zero chamber is attainable for our instruments.

The zero chamber is a one side closed pipe of good magnetic shielding metal to shield the existing outer field. That is at least the earth magnetic field. In addition there may be other interfering fields from the environment. In real world shielding may not be 100 %. A small residual magnetic field remains inside of the zero chamber.



Please see also Application Note PE012 - Zero Chamber - Zero Point Adjustment.

Functional Principle

The graphic shows the simplified structural construction of the Teslameter FM 3002-0,1T. To achieve the outstanding accuracy of the device a multitude of parameters is incorporated. In the graphic thereof are only shown the measurement of the probe temperature and the actual value of the probe signal.

The generated corrections directly affect to the analog signal path. This principle offers considerable advances against solely digital correction techniques. At solely digital correction techniques first the probe signal is digitized with an analog-to-digital converter, corrected at the digital level and then again putted out as an analog signal via a digital-to-analog converter.

Due to the restricted resolution of the converter it is inevitable that steps occur in the output signal. In contrast the Teslameter FM 3002-0,1T with its principle generates a continuous signal response.

The analog output of the Teslameter FM 3002-0,1T is directly feed from the corrected signal and therefor provides full correction and yet a bandwidth of 30 Hz.

Eventually the corrected high precision analog output is sampled with a high-resolution analog-to-digital converter. Out of it the values for the digital display and the serial port are obtained. The settings for integration time and filter affect only the digital path. The program for relative measurement is also generated in the digital path. The analog output is not affected by these settings.

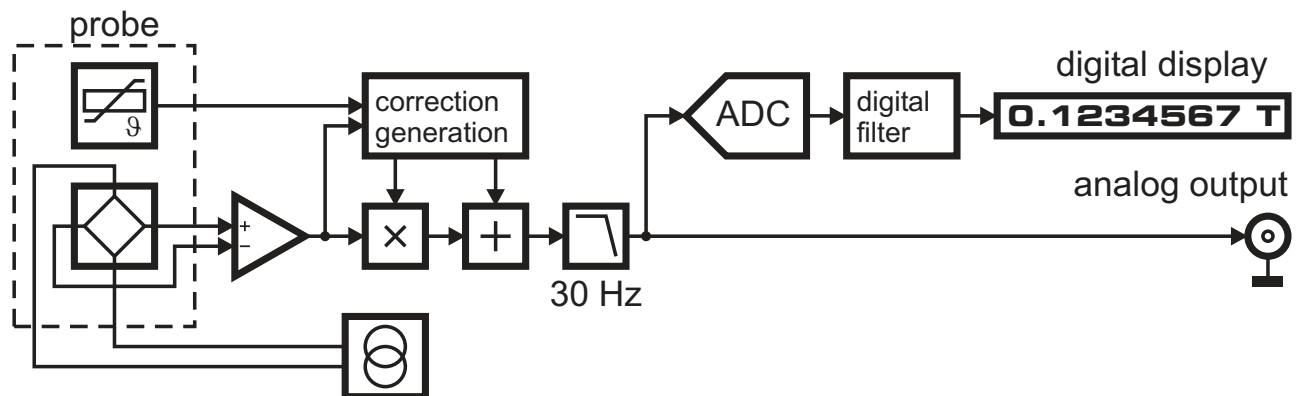

Teslameter FM 3002-0,1T

Measurement Direction and Probes

The probes of the Teslameter FM 3002-0,1T are as system of single axis probes. This means that they can detect fields in parallel to their measuring direction. If the probe is positioned to the field with an angle the measured value is lower than the actual field.

For the Teslameter FM 3002-0,1T there is available a transverse and an axial probe.

Transverse probes have the shape of a flat stem. They measure the field which perpendicular enters the probe. The axial probes are in shape of a round pole. Here the field is measured in the direction of the pole.

These probes made of brass to achieve a higher rigidity.

type

T	transverse probe
A	axial probe

The following images show how the field of a permanent magnet and the field of a coil can be measured with both types of probes

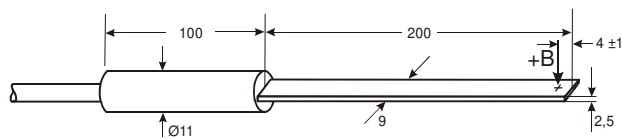
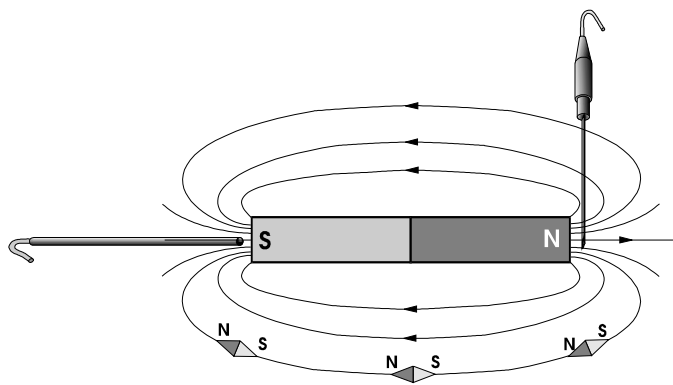

Transverse probe

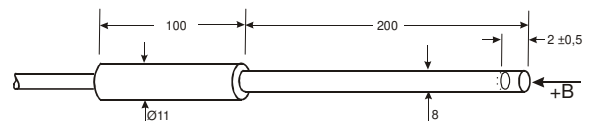
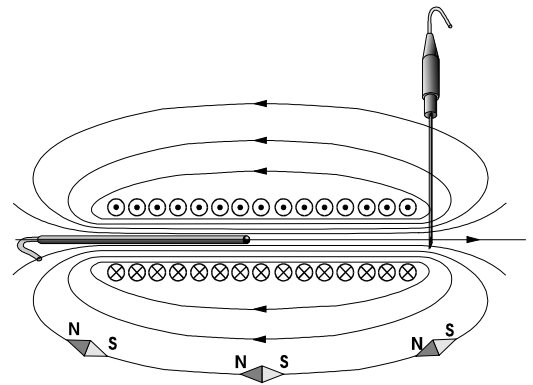

Axial probe

Probe cable length: 2.80 m

Effective area:

Transverse probe	1.5 mm x 3.0 mm
Axial probe	Ø 0.8 mm

Teslameter FM 3002-0,1T

Technical Data

Range: 0 to ± 100 mT	± 1.0 V $\pm 100\,000.00$ μ T	analog output 7 ½ digit display
Non-linearity (incl. probe) (at 23 °C; 20 mT – 100 mT)	≤ 0.05 % of reading, ± 0.05 % of range	
Resolution (display)	0.01 μ T (1/10 000 000)	
Temperature coefficient instrument	≤ 5 ppm/K (0.0005 %/K)	
Temperature coefficient probe at 25 °C Probe T; A	≤ 5 ppm/K (0.0005 %/K)	
Zero drift	≤ 2 μ T/K	
Long-time stability	≤ 0.1 %/year (typ. 0.05 %/year)	
Frequency range	0 - 30 Hz (– 3 dB) DC	Analog output Display
Noise (analog output)	≤ 0.15 μ T _{eff} (1.5 mG _{eff}) (0 - 1 Hz) (50 s)	
Display units	μ T, mT, T, G, kG	
Measuring time	0.1 s to 5 s	
Probe size	9 x 2.5 x 200 mm \varnothing 8 x 200 mm 2.80 m	transverse probe T 1 axial probe A 1 probe cable
Effective area	1.5 mm x 3.0 mm \varnothing 0.8 mm	transverse probe axial probe
Power	115 V~, 230 V~ ± 10 % / 50 Hz - 60 Hz / 20 VA	
Pollution Protection	2 under IEC664 Class I	
Operation temperature	+10 °C to +40 °C	
Storage temperature	- 20 °C to +50 °C	
Max. relative humidity	70 % at +35 °C	
Size (W x H x D)	449 x 104 x 320 mm 483 x 89 x 320 mm	desk top 19" rack
Weight	4.50 kg	

Probe Extension Cord

Additional error	$\pm(10$ μ T + 10 ppm) (cord length 15 m)
------------------	---

Teslameter FM 3002-0,1T

Items Supplied

- | | | | |
|---|-------------------------|---|---------------------------------|
| 1 | Teslameter FM 3002-0,1T | 1 | factory calibration certificate |
| 1 | probe in a probe case | 1 | operating manual |
| 1 | power chord | 1 | CD with software examples |
| 1 | RS 232 cable 10 m | 1 | zero chamber (option) |
| | | 1 | probe extension cord (option) |

Application Notes

On our website (<http://www.projekt-elektronik.com/applikation.php>) under Application you can find many additional documents with information, hints and examples for measuring of magnetic fields.

Questions?

Do you have any question about a measuring task? Call us, we would be pleased to advice you.

As manufacturer of this system we can fulfill your desires about developing probes, changing of measurement range or other needs. Please call us or send us an email.

Gladly we accept your suggestions,

your PE – Team.